

> ERM-EX

Ventilatori elico-centrifughi a sicurezza aumentata

Enhanced safety mixed flow fans



DESCRIZIONE GENERALE

Il ventilatori serie ERM-Ex sono i soli apparecchi elico-centrifughi in linea in esecuzione a sicurezza aumentata "EEx-e" presenti sul mercato. La particolare costruzione ne permette l'impiego in ambienti con atmosfera a rischio di esplosione come: locali batteria, tintorie, autorimesse, etc. Adatti a convogliare aria pulita ad una temperatura da -20°C a +50°C. La serie1 ERM-Ex non prevede la regolazione della velocità.

COSTRUZIONE

- Cassa e girante sono realizzate in materiale plastico antistatico e resistente agli urti.
- Motore elettrico monofase, IP 54, classe B, termoprotetto. Idoneo ad un funzionamento in servizio continuo. Esecuzione EEx-e IIB T3, secondo le norme EN50014/77 e EN50019/77, VDE0170/0171.
- Collegamenti elettrici racchiusi in un contenitore esterno, con grado di protezione IP54.

AVVERTENZE

La scelta del tipo di protezione del motore deve essere effettuata in funzione delle zone di pericolo e delle classi di aree pericolose in cui il ventilatore verrà installato. Solo le autorità preposte possono attribuire le classi e le zone di pericolo alle aree pericolose.

ACCESSORI

- Riduzione.
- Rete di protezione.
- Staffa di fissaggio.

GENERAL DESCRIPTION

The ERM-EX fans are the only mixed flow in line series in increased safety execution "EEx-e" available on the market. The particular construction allows the installation in hazardous environment as: battery rooms, dyeing-plants, garages, etc. Suitable to convey clean air with working temperature from -20°C to +50°C. The ERM-EX series are not suitable for regulation.

CONSTRUCTION

- Housing and impeller are manufactured in sparkproof plastic material resistant to the impacts.
- Single-phase electric motor, IP 54, class B, with thermal protection. Suitable for working in continuous service. Execution EEx-e IIB T3, according to EN50014/77 and EN50019/77, VDE0170/0171 standards.
- Electric connections enclosed in an external terminal box, resistant to atmospheric agents with IP54 protection degree.

ATTENTION

The choice of the motor protection type must be made in function of the zones of danger and the classes of hazardous areas, which the fan will be installed in. Only the competent authorities can attribute the classes and the zones of danger to the hazardous areas.

ACCESSORIES

- Reduction.
- Protection guard
- Fixing clamps.

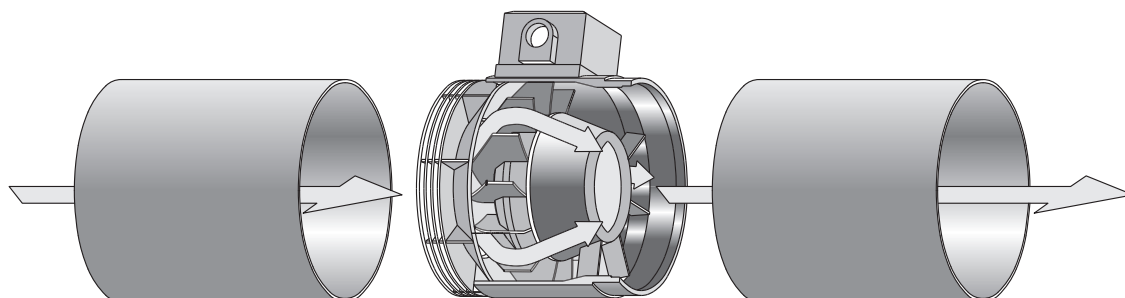

Frequenza 50Hz – Temperatura dell'aria 15°C – Pressione barometrica 760 mm Hg – Peso specifico dell'aria 1,22 Kg/m³ - Alimentazione 230V/1ph/50Hz
 Frequency 50Hz – Air temperature 15°C – Barometric pressure 760 mm Hg – Air specific weight 1,22 Kg/m³ - Power supply 230V/1ph/50Hz

L_p: livello di pressione sonora rilevato a 1,50 m in condizioni standard (vedi legenda a inizio catalogo)
L_p: sound pressure level measured at 1,50 m in standard conditions (see legend at the beginning of the catalogue)

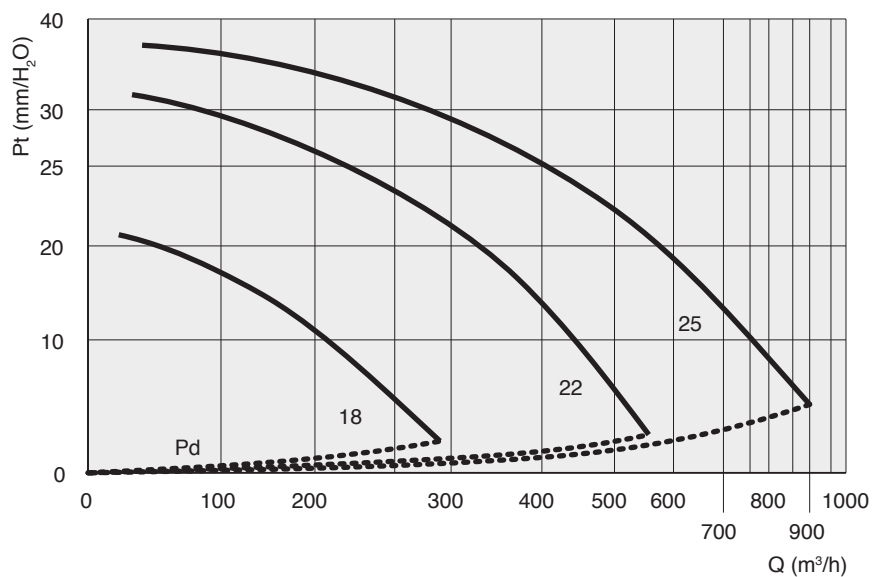

Cod.	Tipo Type	Modello Model	U	rpm	P _m (kW)	In max (A)	IP/CL	L _w * dB(A)
2ME1000	ERM-EX	18	M	2760	0,06	0,28	54/B	66
2ME1002	ERM-EX	22	M	2850	0,2	0,93	54/B	73
2ME1004	ERM-EX	25	M	2890	0,3	1,42	54/B	77

* A bocca libera / Free inlet.

DIMENSIONI *Dimensions*

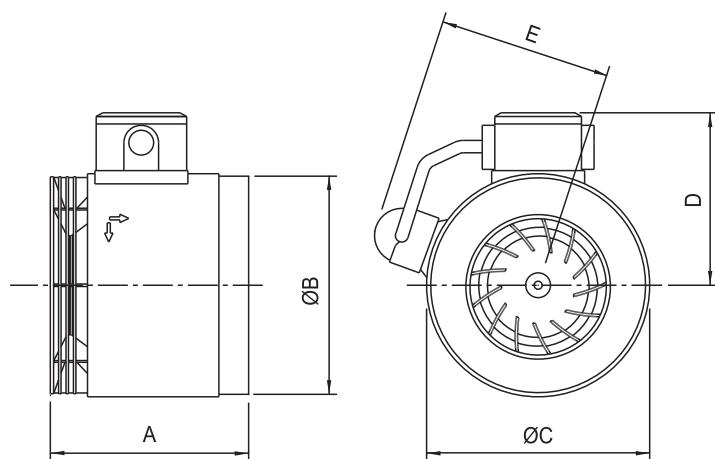

TIPO TYPE	A	ØB	ØC	D	E	kg
ERM-EX 18	161	175	180	137	140	2
ERM-EX 22	175	221	230	165	165	5
ERM-EX 25	205	245	255	178	180	6,5

Dimensioni in mm / Dimensions in mm

RIDUZIONE - REDUCTION

- Permette di raccordare la bocca di mandata al tubo
- Realizzato in materiale antistatico adatto agli ambienti a rischio di esplosione
- *To connect the inlet side of the fan to the duct*
- *Made in antistatic material suitable for hazardous environments*

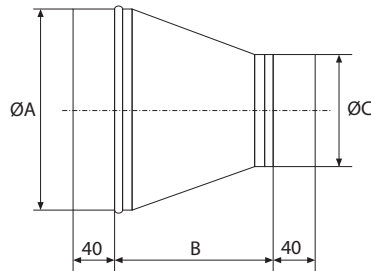

Cod.	MODELLO TYPE	ØA	B	ØC
5RD1001	18/14 REM Ex	179	165	139
5RD1002	18/12 REM Ex	179	186	124
5RD1003	18/10 REM Ex	179	220	99
5RD1004	22/18 REM Ex	225	170	179
5RD1006	22/16 REM Ex	225	198	159
5RD1007	22/14 REM Ex	225	225	139
5RD1008	25/20 REM Ex	249	179	199
5RD1009	25/18 REM Ex	249	206	179

GRIGLIA DI PROTEZIONE - PROTECTION GUARD

- Rete di protezione adatta per entrambi i lati aspirante o premente
- Conforme alla norma DIN EN 294
- Realizzata in metallo
- *Protection guard both for inlet and outlet sides of the fan*
- *Conformity to norm DIN EN 294*
- *Made in steel*

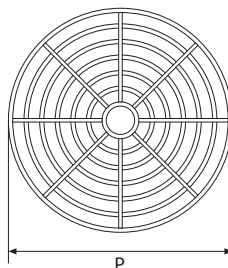
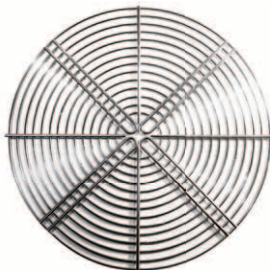

Cod.	MODELLO TYPE	P
5GR1000	GRIGLIA - GUARD 18	178
5GR1001	GRIGLIA - GUARD 22	224
5GR1002	GRIGLIA - GUARD 25	249

STAFFA DI FISSAGGIO - FIXING CLAMPS

- Per l'installazione dell'apparecchio a parete, a soffitto o da appoggio
- Installazione orizzontale o verticale
- Realizzata in lamiera zincata
- *For wall, ceiling or basement installation*
- *Horizontal or vertical installation*
- *Made in galvanized steel sheet*

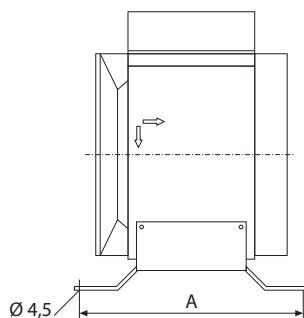

Cod.	MODELLO TYPE	A
5SX0000	STAFFA - CLAMPS ERM Ex 18	187
5SX0002	STAFFA - CLAMPS ERM Ex 22	203
5SX0001	STAFFA - CLAMPS ERM Ex 25	232